



# **SCHARMAN**

## **RK-D-25-40**

# SCHARMAN RK-D-25-40

## FEATURES & ADVANTAGES

- Self propelled system
- Safety standard diesel engine suitable for connection to standard lifting devices
- Gradeability up to 25 degrees with friction wheels
- Safety and simple control system
- Min. at least 12 hours no-break operation by the use of largely dimensioned diesel tank
- Protection certificate ATEX 94/9/EG, equipment group I, category M2
- Capsulated cooling circuit for exhaust gas cooling
- Modular assembly

## DIMENSIONS

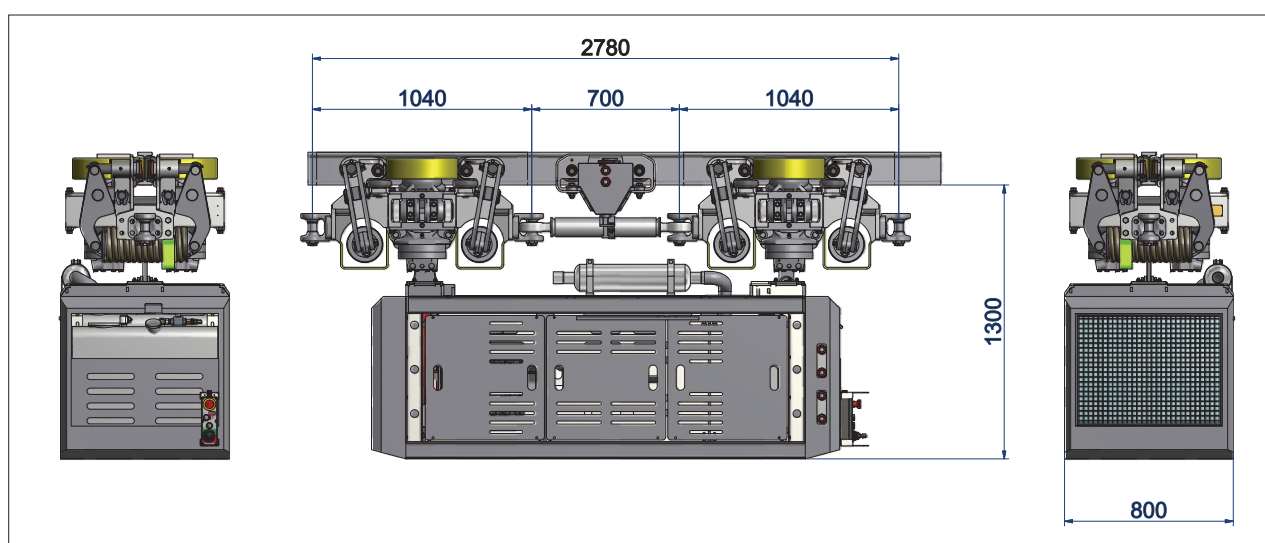

## TECHNICAL DATA

Diesel engine:	Perkins 403D-15
Max. pulling force:	40 kN
Max. inclination:	25 degrees
Max. speed:	0.8 m/s
Min. brake force:	60 kN
Ex-protection class:	Ex I M2 Ex ib I
Certificated by:	ATEX 94/9/EG, equipment group I, category M2